

Cam.st. S9W.



SPECIFICATIONS

Item Group	1.2
Heating element	Internal automatic thermostat controlled
Video Output	Composite video signal: 1.0V(p-p), 75 Ohms, unbalanced
Power Supply	30VAC 50/60Hz
Power Consumption (Max)	14W
Operating temperature range	-30°C ~ +50°C (heating element inside housing)
Operation humidity	Less than 95% Rh (non-condensing)
Weight	5,5 Kg (Incl.Liquid Tank 2,0 Kg)
Material & finish	Stainless steel AISI 316, Electro polished
Protection	IP 66
Dimension (L x W x H)	235 x 140 x 155 mm
Sunshiel Option	Sunshield , PN:095138
Liquid Tank Capacity	2 Litre
Liquid Tank Dimension (L x W x H)	155 x 70 x 220 mm
HERNIS Part Number	095434-xxx/xxx

Note: All data in datasheet are subject to change without any notice.



PART NUMBERING SYSTEM

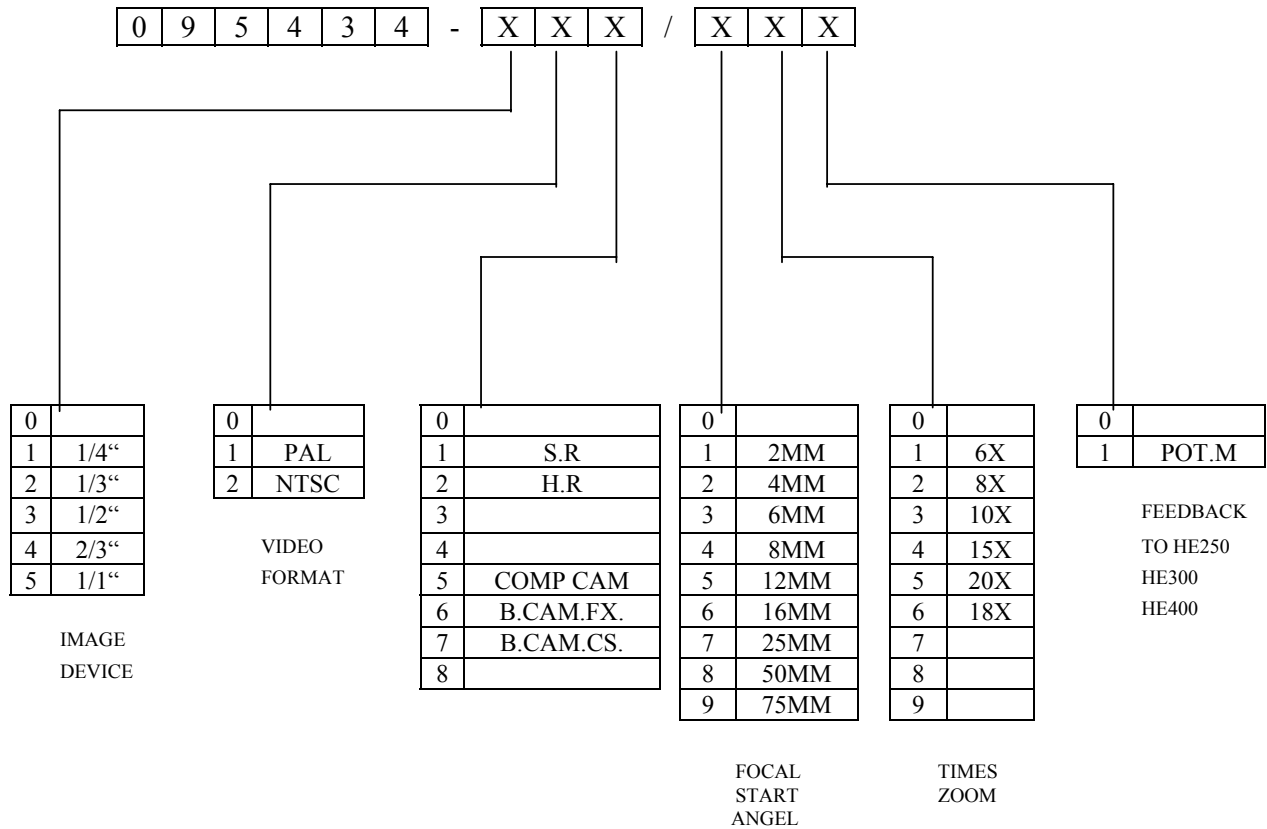

Part Number	Description
095434-115/260	Cam.st. S9W. 1/4",PAL,H.R./4-74mm HE200
095434-115/261	Cam.st. S9W. 1/4",PAL,H.R./4-74mm HE300
095434-125/260	Cam.st. S9W. 1/4",NTSC,H.R./4-74mm HE200
095434-125/261	Cam.st. S9W. 1/4",NTSC,H.R./4-74mm HE300